

MS3-2R Maestro Server Instruction



V1.1
29/11/2010



Copyright © 2010 by CD Innovation LTD. No part of this publication may be reproduced, transmitted, transcribed, stored in a retrieval system or translated into any language or computer language, in any form or any means, electronic, mechanical, magnetic, optical, chemical, manual or otherwise, without the prior written permission of CD Innovation.

DISCLAIMER

CD Innovation makes no representations or warranties, either expressed or implied, with respect to the contents hereof and specifically disclaims any warranties, merchantability or fitness for any particular purpose. Further, CD Innovation reserves the right to make changes in any product, revise this publication and to make changes from time to time in the contents hereof without obligation of CD Innovation to notify a person of such revision or changes.

CD Innovation LTD guarantees product against defects in workmanship and material for a period of 12 months from the date of shipment. In no event shall CD Innovation LTD be liable for any incidental, special, indirect, or consequential damages of any kind. Any damages that CD Innovation LTD is required to pay for any and all causes, whether for negligence, breach of contract, or otherwise, shall be limited to payment made to CDI on the purchase of the specific unit supplied with this instruction.

All brand or product names are trademarks or registered trademarks of their respective companies.

SAFETY INSTRUCTION read before use.

1. The device may only be installed and connected by a CDI certified, professional electrician and according to the relevant regulation in your country.
2. The device is for home or office use only, install it only indoors.
3. Make sure not to pinch cables during installation. If cable is damaged - replace it immediately.
Do not bend the power cord excessively, do not use force on cable and/or connectors.
4. Cut out the circuit breaker before working on or cleaning the device - risk of electric shock
5. Do not make connections while the power is on.
6. Use only with a CDI approved power supply.
7. Do not install near heat sources.
8. Do not expose to direct sun light.
9. Protect the equipment from overheating.
10. Do not expose to water, do not install in damp or wet locations, do not pour any liquid on the device.
11. Never push objects of any kind, or spill liquid of any kind into this product.
12. Do not attempt to service this product yourself. Opening or removing covers may expose you to dangerous voltage points or other risks. Refer all servicing to qualified service personnel.
13. When using this device with a MT104T, first power-up the MT104T and then power-up the Maestro Server.
14. These instructions have to be left with the user of this product.
15. Failure to follow these instructions may cause personal injury, electrical shock, fire, and/or other damage to equipment. .



INTRODUCTION

1.1 Before Installing

- Read this manual cover to cover.
- Pay attention to all warnings and cautions.
- Do not use components not recommend by CD Innovation.
- Do not attempt to service the device yourself. If a problem occurs, contact the manufacturer's authorized service center.

1.2 Unpacking

Open the shipping carton and check the contents. If any items are missing or damaged, contact your dealer immediately.

The package should include the following items:

1. Maestro Server.
2. Power Cord.
3. Power adapter.
4. Bracket wings for wall mount + 4 x m 3/6 screws.
5. Instruction.

1.3 About Your product

Maestro server is based on high performance, fanless, low power computer. Its CPU delivers one of the best performance per watt available in the market today.



TECHNICAL SPECIFICATION

2.1 Specification

Mechanical data:

Housing: Aluminum

Dimensions: (W,H,D) 260 mm x 47 mm x 115mm

Weight: 764g - net, 1680g - shipping weight including accessories and packing material.

Operating element:

On /Off Power Button.

Display element:

1 green power LED.

1 Yellow HD LED

Environmental Limits:

Operating Temp: 0°C to 40°C. (32°F to 104°F).

Operating Humidity: 10% to 85% Without Condensation.

Storage Humidity: 10% to 85% Without Condensation.

Power:

Input: 12VDC.

Power Adaptor: input 100 - 240V AC, output 12V_DC 5A.

Operations:

Power on - by power push button positioned at the side of the housing box.

Power off – by setup page. (Cutting the device's power off or turning the devices off using the power push button can damage the device).

When power is returned, after power failure, the device will revert to its last (On or Off) state.

Setup:

By setup page

Connections:

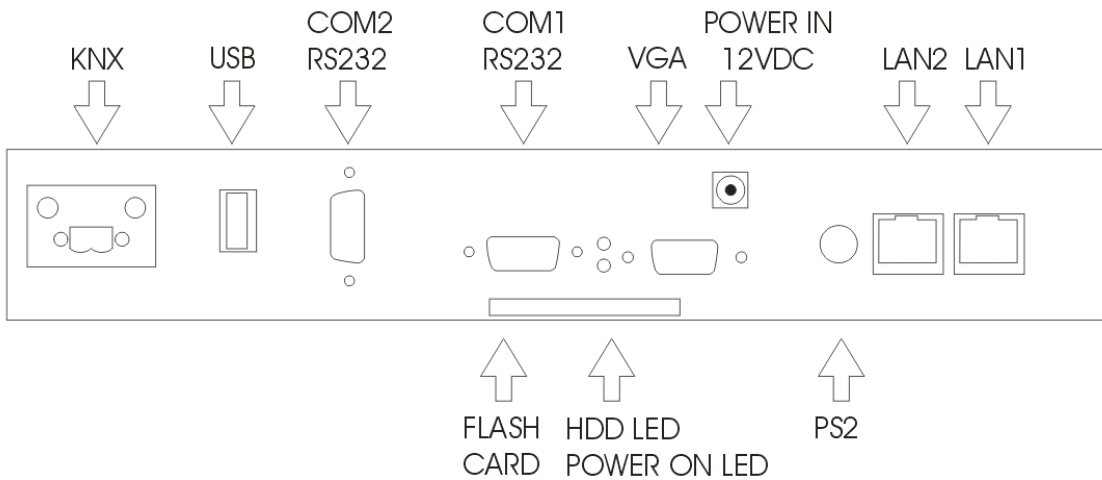

Display: 1x VGA.

USB: 1x.

Ethernet: 2 x 10/100 BaseT RJ45.

KNX: Phoenix connector.

POWER: Low voltage 2.1mm socket.

Serial: COM1: RS232

COM2: RS232 (default). Can be preconfigured by CDI to RS485/RS422 before shipping.

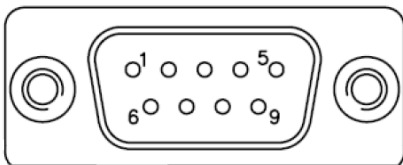

RS232 pin configuration

- 1 – DCD
- 2 – RXD
- 3 – TXD
- 4 – DTR
- 5 – GND
- 6 – DSR
- 7 – RTS
- 8 – CTS
- 9 – RI

RS485*/422 pin configuration (COM2 only)

- 1 – TXD⁻*
- 2 – RXD⁻
- 3 – TXD⁺*
- 4 – RXD⁺
- 5 – +5V
- 6 – GND

Do not select a mode different from the one used by the connected peripheral, as this may damage CPU board and/or peripheral. The transmitter drivers in the port are short circuit protected by a thermal protection circuit. The circuit disables the drivers when the die temperature reaches 150 °C.

RS-422 mode is typically used in point to point communication. Data and control signal pairs should be terminated in the receiver end with a resistor matching the cable impedance (typical 100-120 Ω). The resistors could be placed in the connector housing. RS-485 mode is typically used in multi drop applications, where more than 2 units are communicating. The data and control signal pairs should be terminated in each end of the communication line with a resistor matching the cable impedance (typical 100-120 Ω). Stubs to substations should be avoided.



WARRANTY

- a. The product is warranted, solely to buyers who purchased the device directly from CDI (“buyer”), against material defects in workmanship or materials at the time of shipment from CDI. CDI's sole obligation to buyer with respect to products found not to conform to this warranty, and as to which buyer has fully complied with its obligations. shall be limited, all at CDI's sole option: (i) to repair such Products; or (ii) to replace such Products; or (iii) to credit buyer's account for the net purchase price of such Products (after deduction for any discounts, allowances, and other applicable deductions, including where appropriate incidental costs incurred by CDI); or (iv) to provide buyer with replacement parts which in CDI's judgment are necessary and sufficient for the Products' repair by buyer or buyer's repair agent, in which event such replacement parts shall be provided without charge but any other costs associated with such repairs shall be borne by buyer. As a condition of providing relief under the foregoing warranty, CDI may in its sole discretion require that buyer, at buyer's expense, first return to CDI any Product or part thereof which buyer claims to be defective or otherwise entitled to warranty treatment or which CDI deems necessary to evaluate such claim. No such Product or part shall be returned, however, until buyer has first notified CDI with all practicable speed, and obtained CDI's authorization therefore. In lieu of requiring return, CDI may impose other requirements, such as but not limited to, detailed technical and diagnostic reports and/or third party verification.
- b. Notwithstanding the preceding subparagraph (a), CDI shall have no liability or obligation whatever, and buyer shall be solely responsible for and shall indemnify and hold CDI harmless from any claims, losses, expenses, or allegations, respecting any Product or part as to which: (i) buyer fails to comply fully with any and all requirements imposed under subparagraph (a) or otherwise implemented by CDI pursuant to this Agreement; or (ii) such Product, or part, evidences any sign of mishandling, misuse, abuse, damage in transit, exposure to or operation under circumstances for which it was not designed and intended or which is negligent or contrary to CDI's instructions, or other contributing cause other than a material defect in CDI's workmanship or materials at the time of delivery to RESELLER. CDI MAKES NO WARRANTY RESPECTING THE PRODUCTS EXCEPT THE FOREGOING UNDERTAKING. CDI DISCLAIMS, AND RESELLER WAIVES, ANY AND ALL IMPLIED WARRANTIES, INCLUDING WITHOUT LIMITATION IMPLIED WARRANTIES OF MERCHANTABILITY OR FITNESS FOR A PARTICULAR PURPOSE. CDI SHALL UNDER NO CIRCUMSTANCES BE LIABLE IN CONTRACT, IN TORT, OR OTHERWISE FOR SPECIAL, INCIDENTAL, OR CONSEQUENTIAL DAMAGES, WHETHER OR NOT FORESEEABLE. THE FOREGOING DISCLAIMERS AND WAIVERS SHALL APPLY AT ALL LEVELS OF DISTRIBUTION.
- c. The software running this device and of Maestro designer (“the software”) are WITHOUT ANY WARRANTY; without even the implied warranty of MERCHANTABILITY or FITNESS FOR A PARTICULAR PURPOSE. THERE IS NO WARRANTY FOR THE SOFTWARE. CDI PROVIDES THE SOFTWARE "AS IS" WITHOUT WARRANTY OF ANY KIND, EITHER EXPRESSED OR IMPLIED, INCLUDING, BUT NOT LIMITED TO, THE IMPLIED WARRANTIES OF MERCHANTABILITY AND FITNESS FOR A PARTICULAR PURPOSE. THE ENTIRE RISK AS TO THE QUALITY AND PERFORMANCE OF THE SOFTWARE IS WITH YOU. SHOULD THE SOFTWARE PROVE DEFECTIVE, YOU ASSUME THE COST OF ALL NECESSARY SERVICING, REPAIR OR CORRECTION. IN NO EVENT WILL CDI and/or ANY COPYRIGHT HOLDER, BE LIABLE TO YOU FOR DAMAGES, INCLUDING ANY GENERAL, SPECIAL, INCIDENTAL OR CONSEQUENTIAL DAMAGES ARISING OUT OF THE USE OR INABILITY TO USE THE SOFTWARE (INCLUDING BUT NOT LIMITED TO LOSS OF DATA OR DATA BEING RENDERED INACCURATE OR LOSSES SUSTAINED BY YOU OR THIRD PARTIES OR A FAILURE OF THE SOFTWARE TO OPERATE WITH ANY OTHER PROGRAMS), EVEN IF SUCH HOLDER HAS BEEN ADVISED OF THE POSSIBILITY OF SUCH DAMAGES.