

BREEZA

Manual



CONTENTS

Section 1: Technical Product Information.....	3
Product and Application Description.....	3
Application Programs.....	5
Example of Operation.....	6
Installation Instructions.....	7
Technical Specifications.....	7
Section 2: Application Program Description.....	10
General description.....	10
Commissioning.....	12
Operating.....	14
Communication Objects.....	20
Parameters.....	23
Section 3: Instructions for Installation and Operation.....	36
Installation Instructions.....	36
Dimensions.....	38
Mounting.....	38
Wiring.....	40
Wiring diagrams.....	41

Technical Product Information

BREEZA Multi functions room controller 5x 230V

ENFV1TAA

Product and Application Description

The BREEZA controller is a complete room temperature and energy control unit, which combines the human interface; logic and power supply (230 Volts), in one unit.

Available in Titanium white color.

The BREEZA controller is a two-step temperature control governor (thermostat) that can be employed for both heating and cooling tasks as well as any combination thereof.

Along with the temperature control, The BREEZA controls over the Light's (via EIB bus and external actuator) as well as monitoring occupancy and the status of the door or window (via external sensors connected directly to the BREEZA).

The respective application program compares the actual room temperature measured by the temperature controller to the specified set point and generates the required regulation value. The regulation value is controlling over the internal relays, which are connected, direct to the Cooling and Heating elements.

The operation of the unit is clear and self-explanatory.

User interface contains 8 push buttons and 6 LED's for indication of the current status of each function.

Transparent cover allows matching underneath signs to the push buttons and LED's. Each panel that is been selected, has a decal with all the graphic symbols for Installation under the front clear plastic at the controller operation panel.

Three-digit LCD display presenting the Room actual temperature or the required Set Point.

Optional by ETS software set up are Buzzer sounds on each key press for the operator feed back.

Various functions are available for the push buttons among them:

Setting the required set point, selecting the fan speed, switching between Heat, Cool or Fan modes, switching lights and switching the HVAC system.

The actual functionality of the push buttons is defined with the ETS application program dependent of the HVAC system and the required control functions.

The BREEZA Temperature controller is mounted into side-by-side two box mounts, Ø60 mm.

A back plan frame is mounted on top of the two box mounts with 4 screws.

The left mount box is for the 230 Volts AC it has a female 7 terminals 230 Volts AC connector and all 230 Volts AC connections are made to this connector.

The Right mount box is for the Low Voltage wiring: Presence detector, Door or Window microswitch, remote temperature sensor and EIB BUS wires.

The BREEZA comes complete with components:

- 1 Back Plan Frame.
- 1 BREEZA temp. Controller.
- 1 optional set of Decals (Labels) to set the functions on each key (have to be ordered separately P/N - PIC1).



- 1 Low Voltage connector (5 Pin's)
- 1 mounting accessories (screws)
- 1 installation instructions
- 4 mounting screws

It has five internal relay 230 volts AC (outputs) to switch on/off the heating and cooling loads.

Each of the (Relays) outputs can be assigned various tasks depending on the application program used.

The BREEZA Temp. Controller consists of the device (hardware) and its application programs (software).

It has low voltage inputs for occupancy control logic and optional remote room temperature sensor.

With the ETS (EIB Tool Software) the Panel and the application program are selected, its parameters and addresses are assigned appropriately, and downloaded to the internal BIM.

Technical Product Information

BREEZA Multi functions room controller 5x 230V

ENFV1TAA

Application Programs

First, the panel number and type select the application.

The panel will define the Heating and Cooling mode, Fan control, Override, light, and Turbo operations.

Second, The rest of parameters can be set.

Parameters are divided to five groups, each group is set by different ETS page as follows:

Basic page	General Settings page	Object Transmission page	Presence Function page	Central Control page
Panel Number	Celsius / Fahrenheit	Set Point Temperature	Use Presence Detector	Set-Back offset
Local temperature control	Cyclic Time, Temperature Transmission	Power Status	Connection type	Set-Back Temp on Cooling
Function of the system	Temp. Change that generate transmission	Stand-By Mode	Transmit Status over the Bus	Set-Back Temp on Heating
Heat / Cool Switch	Remote Control code	Heat Mode	Contact type N.O. / N.C.	Cooling temp on Night mode
Fan Operation mode	Minimum Set-point on Cooling	Cool Mode	Micro-switch options	Heating temp on Night mode
Number of Fan Speed	Maximum set-Point on Heating		Stand-By on Heating	Emergency temp. for Cooling
Number of Stages	5 Min. Anti- Short cycle		Stand-By on Cooling	Emergency temp. for Heating
Buzzer	Air Conditioner type		Time Delay for Air-Condition	
Display operation			Time Delay for Light	
System State after power Shut Down				

BREEZA Multi functions room controller 5x 230V **ENFV1TAA**

Example of Operation

The following figure illustrates typical use of a BREEZA and the devices related to it.

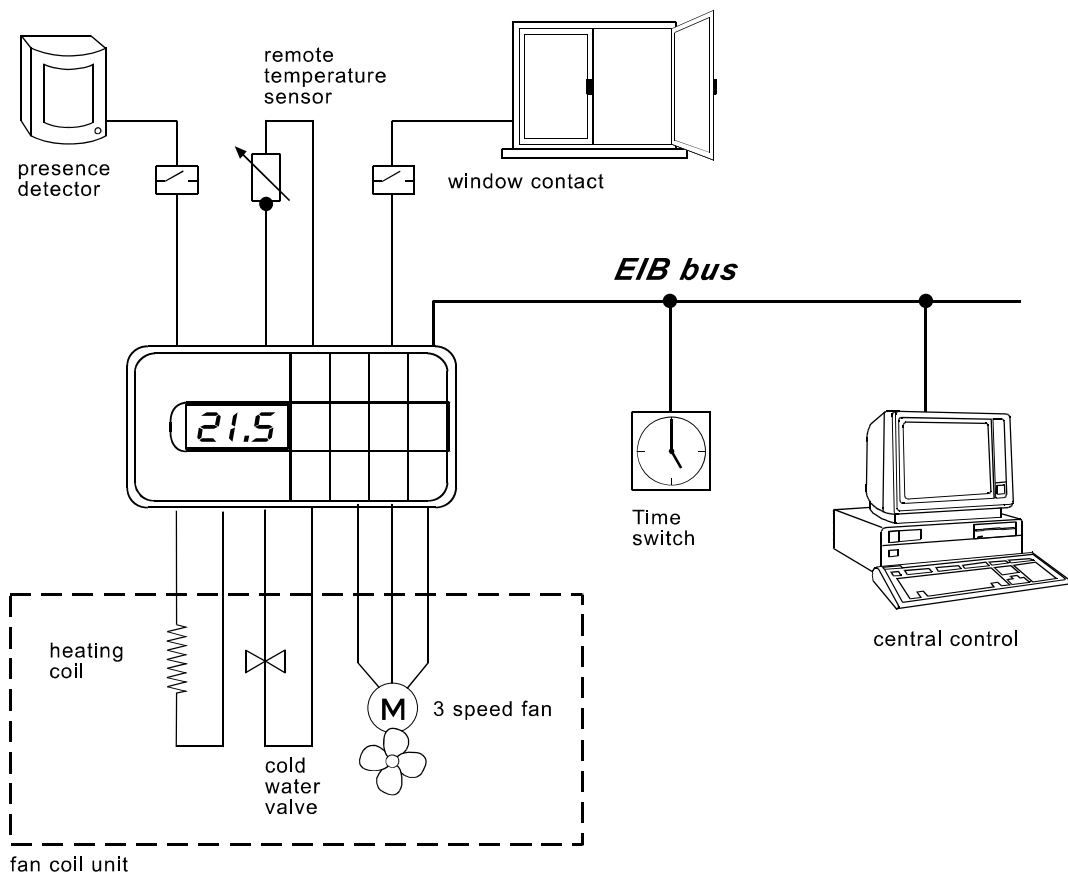

Technical Product Information

BREEZA Multi functions room controller 5x 230V

ENFV1TAA

Installation Instructions

The device may be used for permanent interior installations in dry locations within box mounts.

WARNING

- The device must be mounted and commissioned by an authorized electrician.
- The prevailing safety rules must be heeded.
- The device must not be opened.
- Always Load the appropriate ETS application to the Breeza before connecting power terminals 4 to 8.

A device suspected faulty should be disconnected and returned to the local Ardan office.

The device has two mounting boxes; the left one is for 230 Volts AC. The right box is for extra low voltage (ELV) terminals and cables.

Low voltage cables must not be mounted in left box mounts with the 230 V.

Technical Specifications

Power supply

Model ENFV1TAA: Power line of 230 +/- 10% Volts A.C. 50 – 60 HZ.

Model ENFL1TAA: 24 +/- 10% Volts AC from the HVAC unit Transformer.

Temperature measurement

Regulation range: 5 ... +32 degree Centigrade

- Resolution: 0,1 Deg. K
- Precision due to temperature of the sensor: $\pm 1\%$ at reference conditions.

Control elements

Total of 8 push button for various functions.

Switches are configured per application, which is defined by the panel selection.

Switches can have combinations of the following features:

- 2 push buttons used for manual set point adjustment, in 0.5 degree steps.
- 2 push buttons used for increase / decrease three Fan speeds.
- 2 push buttons for switching between 'Fan continuously on' and 'Fan auto'.
- 1 push button for toggling between 'Fan continuously on' and 'Fan auto'.
- 2 push buttons for switching between Heating, Cooling and Ventilation modes.
- 2 push buttons for switching between ON and OFF.
- 1 push button for toggling between ON and OFF.

Technical Product Information

BREEZA Multi functions room controller 5x 230V

ENFV1TAA

- 2 push buttons for switching light ON and OFF over the EIB Bus.
- 1 push button for toggling light ON and OFF over the EIB Bus.
- 1 push button for override.
- 1 push button for Turbo mode.

Display elements

- 6 Red LED 's for status displaying.
- 3 Seven Segment LCD display for displaying the Temperatures + decimal point.

Outputs

Model ENFV1TAA.

- Five 230VAC relay outputs (Volts contacts).
 - Rated voltage: AC 230 +/- 10% Volts A.C., 47 ... 63 Hz.
 - Rated current: 6 A resistive loads.
 - Breaking current at AC 230 V: resistive load 0,01 ... 6 A, inductive load $\frac{1}{4}$ H.P.

Model ENFL1TAA

- 5 outputs (volts contacts)
- Rated voltage: 24 +/- 10% Volts A.C. , 47 ... 63 Hz.
 - Rated current: 2 A resistive loads.
 - Life time Electrical 1x100,000 operations.
 - Life time Mechanical 1x10,000,000 operations.
- Power supply for presence detector 12 VDC, Maximum 40m Amps

Note: The outputs can operate: Compressor, Reversing valves, water valves, Fan motors and Electrical heaters. The type of the load is defined by the application selected.

Inputs

- Presence Detector: Dry contact.
- Door/Window switch: dry contacts.
- Remote Temperature sensor 10K Ohm at 25 Deg. C.
 - The sensors with pre-formed cable have to be ordered from ARDAN P/N "RTSRxx"

Communication

EIB – European Installation Bus.

Connections

- Power supply line and Load circuit, screw plug-in terminals:
 - ø0,5 ... 1,5 mm² (16AWG) flexible conductor.
- EIB BUS TERMINAL - screw-less connection block ø0.6...0.8 mm single core.

Technical Product Information

BREEZA Multi functions room controller 5x 230V

ENFV1TAA

Physical specifications

- Plastic casing.
- Dimensions: W x H: 151.5 x 80.5 mm - Depth: 32 mm.
 - Mounting depth: 11 mm.
 - Weight: approx. 222 g.
- Installation: mount over back plate connected to two in wall boxes mounts \varnothing 60 mm, 40 mm deep.
- Fire load: approx. 1,050 KJ \pm 10 %.

Electrical safety

Equipment tested according to EN 60730-2-9:95+A1 (96)+A2 (97).
EN 60730-1:00, EN 60730-2-1:97.

Components withstand safety standards as follows:

- Fouling class: 2
- Protection according to EN 60529:
- Over voltage class: III
- Bus: safety extra low voltage SELV 24 V DC.
- Insulation rating: according to IEC 664 and pr EN 50178.
 - Rated insulation voltage: $U_i = 250$ V
 - Casing: basic insulation for U_i .
 - Casing and cable ring: basic insulation for U_i .

Electromagnetic compatibility

Complies with:

1. EN 60730-1:00.
2. EN 60730-2-9:95+ A1 (96)+A2 (97).
3. EN 50090-2-2:11.96 + A1:2002.
4. EN6100-4-2 (ESD) Air +/-8.0KV; Contact +/-6.0KV.
5. EN61000-3-2:00 (Radiated Immunity) 10V/M.
6. EN61000-3-3: 95+A1 (01).

Environmental specifications

- Climatic conditions: EN 50090-2-2, EIB-manual.
- Ambient temperature operating: - 5 ... + 45 °C.
- Storage temperature non-op.: - 25 ... + 70 ° C.
- Relative humidity (non-condensing): 5 % to 80 %.

Certification

EIB certified.

CE norm

Complies with the EMC regulations (Residential and functional buildings), and low voltage regulations.

Application Program Description

BREEZA Multi functions room controller

BREEZA_EXPORT_6_2 & 3

Product family: HVAC
Product type: Multi function room controller
Manufacturer: Ardan P.I.C
Name: BREEZA Multi functions room controller 5x230V.
DELTA studio, titanium white Order-no.: ENFV1TAA

General description

The BREEZA Multi function room controller is designed for: Fan Coils, Heat pumps, Under Floor Heating and other commercial and residential HVAC equipment with Light control¹ and Energy control in the room.

The application enable to display ambient or set point temperature. Temperature is displayed on a highly visible 3 seven-segment LCD display.

Large push buttons and Audible emit a beep when pressed for Precise Application controls.

For accurate function selection, a large, bright LED's indicates which button is pressed to shows each function operation.

The Application offers intelligent, multi-function operation. Comes in different operation panels. **A “panel” defines specific configuration of the 8 pushbottuns and LEDs.**

The application controls the five internal relays.

The ETS application has five screens including more then 40 different parameters; **it is cardinal to set the parameters in the following order:**

First, the panel (specific configuration of the 8 pushbuttons and LEDs) must be selected and then all other parameters.

The application is for heating, cooling or combined heating and cooling tasks controlling a HVAC system connected directly to the controller, it enables remote control and monitoring of most of its functions and it also sends switching telegrams (on/off) to Bus devices e.g. light control and Under Floor Heating contactor.

The application program compares the actual temperature measured by the temperature controller with the desired set point and operates the Relay's accordingly.

Unoccupied Stand by setting is available to reduce energy consumption when zone is not in use.

¹ Via external EIB output devices

Application Program Description

The Multi function room controller stores in EEPROM the application parameters and the operating actual parameters like:

Set point, fan speed etc' which assure smooth continuation of operation even after power failure or Communication loss of the BUS.

Regulation

The BREEZA application can be employed to pure heating or cooling tasks or to a combination of both with or with out LIGHT control and energy saving options.

When making a combined heating and cooling task, the application either runs in the heating, cooling or ventilation mode.

Switching between heating and cooling can be established automatically or manually at the controller panel with the buttons or via the Bus (communication object).

Response to Bus voltage failure and restoration

1. After main line voltage failure (230 Volts AC), A parameter in the application defines the operation of the controller after power fail. The parameter defines if the controller will operate in the same way that it was just before the power fail, or it will be OFF after the restoration of the power.
All other setting values will be the same after the power restoration.
2. If the communication to the Bus is interrupted, the Controller will continue the operation as a stand alone controller, while the application and all parameters are still working and operating just as they were before the Bus failure.
Changes that will be made at the front panel of the controller will take place right a way.
After communication restoration, all changes that were made locally at the front panel will be updated to the BIM.

There is no special response of the controller on Bus voltage failure.

In case that the main power line (230 Volts) fails and the Bus is still operating, all changes that were sent on the Bus will be stored in the controller, when the main power will restored, all the data that arrived from the Bus will be updated to the controller EEPROM and the application and operation of the controller will perform accordingly.

If a presence detector is connected directly to the controller,

After a power up, the monitoring of the presence detector by the controller is delayed in few minutes until the presence detector finishes the warm-up procedure and send signal of "no presence" state.

The delay takes 3 minutes and applies only after power is connected to the unit.

Energy Managment Temperature Profile

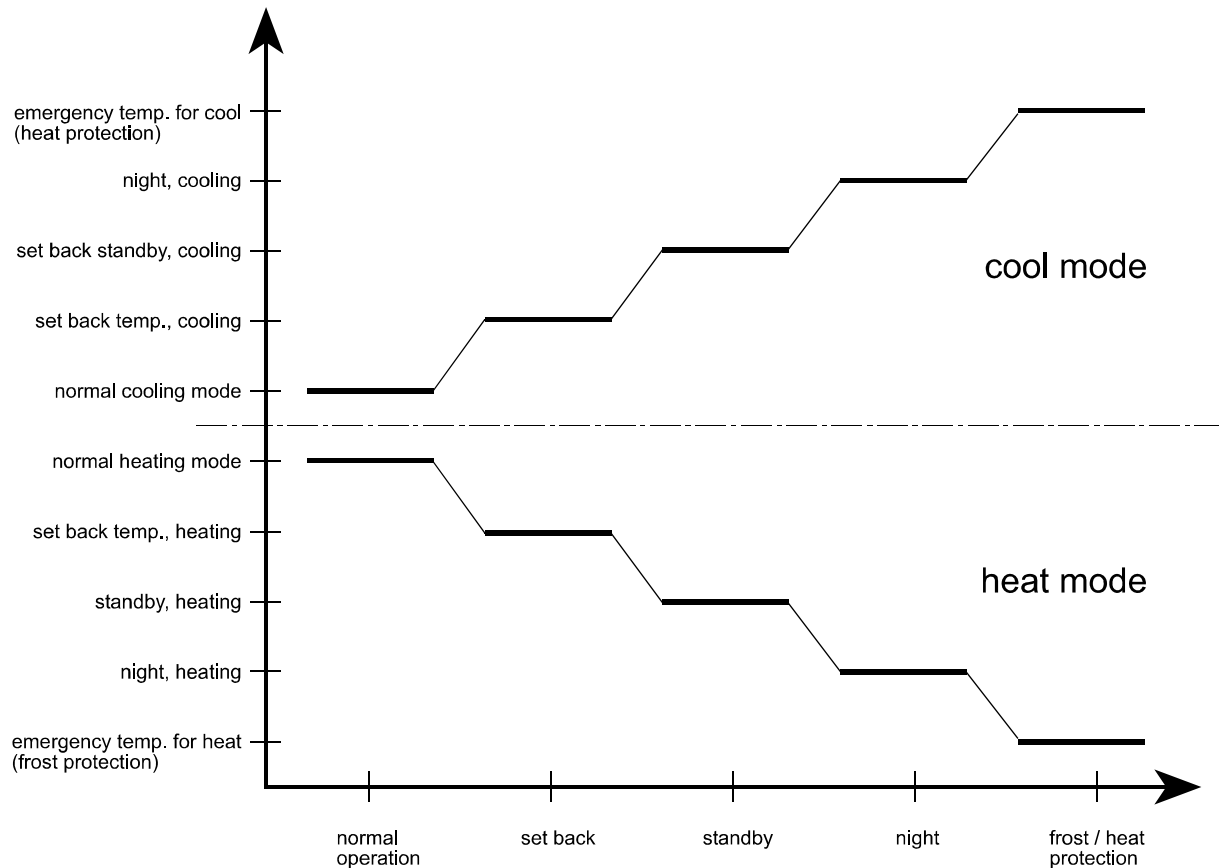

Commissioning

Unless required otherwise by the client, the controller comes with a factory programmed default application.

The preset application allows the controller to operate with out connecting it to the Bus and before down loading the final application. The controller acts as a stand along controller that allows the commissioning of the HVAC unit even before connecting the communication.

The default application has the very basic application features with:

- Panel number zero (0),
 - o Buttons function (left to rite):
 - increase set point temperature, Decrease set point temperature
 - increase Fan speed, Decrease Fan speed
 - Heat, Cool
 - Power On, Power Off.

Application Program Description

BREEZA Multi functions room controller

BREEZA_EXPORT_6_2 & 3

- Local temperature control - Enable
- Function of the system – Heating and Cooling
- Heat/Cool switch control - Local and remote changeover.
- Fan operation mode - continues.
- Number of fan speeds – three
- Number of stages - One
- Buzzer Enabled.
- Display operation – Display set point and on pressing display ambient
- System state when power is up – last state
- Units of measurement – Celsius
- Duration of time between cyclic temperature statuses transition – No cyclic transition.
- Temperature change that generates automatic transmission on the bus – Disable
- Remote control channel – remote control not used
- Minimum set-point on Cooling 10 Celsius
- Maximum set-point on Heating – 32 Celsius
- 5 minutes delay before compressor run again – Disable
- Air conditioner type – Direct type
- Winter Summer control – Disable
- Object transmission control page – all parameters are set to Disable
- Use presence detector – No
- Micro switch options – No micro switch connected
- Set back temperature offset on cooling – disabled
- Set back temperature offset on Heating - Disabled
- Cooling temperature on night operation mode – Off
- Heating temperature on night operation mode - Off
- Emergency temperature for cooling –Do not use emergency mode on cooling
- Cooling temperature on night operation mode - Off
- Heating temperature on night operation mode – 7 Celsius
- Emergency temperature for heating 7 Celsius
- No Anti- short cycle delay.
- No temperatures limit.
- No presence detector
- No Door or window switches.

Application Program Description

BREEZA Multi functions room controller

BREEZA_EXPORT_6_2 & 3

Operating

The application is set by use of the ETS ,(ETS2 v 1.2 or higher), program.
At the ETS, 5 screens define the application and all relevant parameters.

Panel type selection

First, the panel type must be selected out of the 25 available panels.

The panel type (number) defines the application features and operation, Man machine interface by the task of each button and indication light.

Only then, the parameters that need to be changed from the original default setting should be changed according to the application by using the parameters at the 5 screens.

The controller application can be set for operation in the HEAT mode, COOL mode and Ventilation mode.

At each of the above mode, the FAN can be set to one of the three modes of operation, were the FAN can:

1. Work continuously = Fan will operate all the time even if there is No Demand for cooling or heating.
2. Work "on demand" = automatically, every time that a demand will start, the Fan will start with the heating or cooling element.
3. Work Continuously on Cooling and on demand during Heating.

The application defines which type of HVAC equipment is being operated and will organize the relay operation and task accordingly.

Light control can be added at panels were a light switch is available or at all other panel if the energy saving elements were selected.

Application Program Description

BREEZA Multi functions room controller

BREEZA_EXPORT_6_2 & 3

Starting Operation:

Pressing the “power” button at the Multi function room controller panel turns ON and OFF the HVAC controller.

When pressed ON, an LED above the power button is illuminated.

Some panels having only one power button, were the same button is use for turning ON and turning OFF. Other panels having two power buttons were the upper one is to turn ON and the lower one is for turning OFF.

Heat – Cool operation:

Pressing the “Heat” or “Cool” buttons at the Multi function room controller panel turns ON the “Heat” or “Cool” mode of operation.

When one of the “Heat” or “Cool” modes are selected, the appropriate LED indication above the “Heat” or “Cool” buttons is illuminated.

When none of the “Heat” or “Cool” modes is selected, the unit will operate only in the ventilation mode.

Multi- speed Fan Control:

When the application panel offers multi- speed; a two or three fan speed can be selected. On panels without Fan speed, only one speed is available.

Fan Operation:

Fan “AUTO/ON” buttons select whether the fan runs continuously or if it cycles with the demand. Red “LED” illuminates to indicate the option selected.

When fan switches are not provided, the fan operation is as specified in the panel and parameters screen.

Under-floor Heater Operation:

This option should be defined in Panel number 10 of the application program.

The heater operates only if the thermostat is in “Heat” mode, and measures the room temperature. If the unit is supplied with a remote under-floor temperature sensor, then the under floor remote sensor is been used as a safety element, if the under floor heat temperature rise above the limit it turns OFF the heating element by sending the ON/OFF telegrams via the Bus, by using the Under floor heat control object.

If that temperature is lower than set point and also if the room ambient temperature is lower than defined Set-point, the Thermostat sends an “ON” telegram to the heater element.

The thermostat sends switching “OFF” telegram when the under-floor heater temperature becomes equal or higher than factory defined, or when the room Ambient temperature is higher than the set point defined.

Application Program Description

BREEZA Multi functions room controller

BREEZA_EXPORT_6_2 & 3

Temperature Display:

The Application can be program to display temperature in either Fahrenheit or Celsius. As only one temperature can be display at one time on the display.

The multi function control can show both of the set point and ambient temperature by switching between them when the UP and DOWN buttons are pressed simultaneously.

The application defines the main display and the secondary display (background). Either of the Ambient temperature or Set point temperature can be set as the main or the secondary display.

The main temperature display may be temporarily masked for two seconds by the secondary temperature display.

When the main display is the set-point, by pressing both the Temperature “UP” and “DOWN” buttons simultaneously, the ambient temperature will be on the display as long as both buttons are been pressed and then for two seconds after the buttons were released.

If the ambient temperature display is the main one, then the set-point temperature can temporarily mask it by pressing either the temperature “UP” or the temperature “DOWN” buttons.

The set-point temperature will be on the display as long as one of the buttons is been pressed and then for two seconds after the button was released.

When the secondary Temperature is on the display, it will blink.

The temperature setting can be done in two ways:

- By pressing the UP or DOWN buttons momentarily, each press will increase or decrees the temperature in one Deg. C or Deg. F.
- By holding the UP or DOWN buttons pressed continually, the Temperature set-point will increase or decrees automatically in a rate of one Degree per 0.5 second.

MCO (Manual heat/cool Change Over) Operation:

MCO applications have a “HEAT” and a “COOL” button.

It must be manually set to heating, cooling or ventilation or it can be controlled from remote via the Bus.

When none of the Heat or Cool buttons are been pressed, the controller will run in ventilation mode.

ACO (Automatic heat/cool Change Over) Operation:

The controller will do changes from heating to cooling on ACO applications, Only automatically.

Application Program Description

BREEZA Multi functions room controller

BREEZA_EXPORT_6_2 & 3

Emergency Override:

The application can have one or two of the emergencies override options:

- Emergency override for Heating (Freeze) protection.
- Emergency override for Cooling (Too Warm) protection.

These options monitor Room temperature even when power button is turned "OFF".

Override:

When an OVERRIDE BUTTON is provided. The application overrides night setback for two hours after being activated by pushing the OVERRIDE" button.

In night mode the Application displays the original set point temperature, but regulation of the temperature at the controller is done according to the *Night set point value*.

When the override button is pressed, the original set-point returns to control the regulation, same as at the normal day operation, for two hours.

Application Download:

After setting the panel and the parameters, the application should be down loaded to the controller memory.

When connecting the Bus, the controller gets the application data from the Bus and enters it to an internal EEPROM memory at the controller.

The new application will be inside the EEPROM till the next time a down load will happen.

Energy saving

1. The controller can be equipped with a presence detector.
The presence detector can be an internal one, (connected directly to the BREEZA controller) or remote presence detector on the Bus.
When only a presence detector is connected, the application can be set to Enter in to the stand – by mode, or to turn OFF the controller.
2. The controller can be equipped with a presence detector and a door switch.
This application is good for Hotel rooms or any rooms were people are sleeping.
The Door switch and additional logic raises the reliability of presence Detection
3. The controller can be equipped with a window switch.
In this application, when the window switch changes to "open" position, the Controller turns OFF all relays.

Stand by mode:

The Stand By Mode is used along with the presence detector.

When the presence detector detects that no one is in the room for the delay time period that was set in the parameters, the controller enters the stand by mode.

In the stand by mode:

If the controller is in the Heating mode, the controllers reduce the set point in a value that was defined as the Stand by setting in Heating.

If the controller is in the Cooling mode, the controller increases the set point in a value that was defined as the Stand by setting in Heating.

Night mode

The Night Mode allows the controller to operate in a reduced energy usage.

Receiving a remote commands via the Bus activates the Night mode.

When activating the Night mode:

In Cooling mode, the controller will change the set point value to be the one That was set at the Cooling Temperature on Night Operation Mode parameter.

In Heating mode, the controller will change the set point value to be the one That was set at the Heating Temperature on Night Operation Mode parameter.

Pressing the Override button operates the Override mode for two hours.

During the two hours, the controller will return to the original set point.

After the two hours period the temperature controller automatically returns to the night mode.

The Override button allows a central control of all temperature controllers running the night/bank holiday mode while people who want to continue working can still maintain convenience temperature by operating the Override button.

If a presence detector function is used, the presence detector signal is operated as Override; The controller will enter to night mode only when the presence detector signals a "No presence" constantly for the delay time that was set in the parameters.

Window Protection

The BREEZA application can have a window switch input.

Upon activating a window switch by opening the window the Multi function room controller will switch all relays output OFF.

At the PARAMETERS screen the type of the window switch is defined to be a N.O. or N.C. type.

Once the window is closed again, the Multi function room controller returns to the mode used before the window protection was activated.

Emergency Heat:

Once the Ambient temperature drops below the pre set value at the PARAMETERS screen, the Heating elements are turning ON immediately.

This feature works even when the Controller is in the OFF mode.

Emergency Cool:

Once the Ambient temperature rises above the pre set value at the PARAMETERS screen, the Cooling elements are turning ON immediately.

This feature works also when the Controller is in the OFF mode.

Room Temperature

The Multi function room controller integrated temperature sensor measures the actual Room temperature. Or with an optional Remote temperature Sensor.

The actual Room temperature is sent automatically by the communication as the "Ambient temperature" according to the selection of ETS parameters,

On the below events:

- When switching ON the device - on Bus voltage restoration
- On each change of the actual temperature by the preset value of Deg. K
- Cyclic according to a fixed time base that is predefined at the Object transition control screen.
- At any case the actual temperature can also be manually read via the Bus.

Manual set point adjustment:

Two buttons UP and DOWN are used to set the desired temp. Set point.

The specified set point, is the temperature that is to be met by regulation, constitutes of the set-point base, the manual set-point adjustment as selected with the temperature controller's two buttons, and the actual operating mode.

The set-point is sent automatically by the communication as the "Temperature set point" on the following events:

- On switching on the device - on Bus voltage restoration
- On operating the manual set-point adjustment (UP and DOWN buttons).

The set point can be read manually via the Bus.

Set point base:

Range: 5 ... 32 °C

Default: 21 °C

Night mode set-point adjustment:

Heating range: 5 °C ... 20 °C Default: 16 °C

Cooling range: 25 °C ... 36 °C Default: 28 °C

Under Floor temperature setting:

The temperature for the Underfloor heater safety control is a factory defined Temperatures as follows:

Underfloor heater switch ON when temperature reaches 20 °C.

Underfloor heater switch OFF when temperature reaches 30 °C.

The underfloor heater is switched only if the thermostat is in "Heat" mode.

Other safety temperature settings are available by special request.

Neutral zone = Dead Band

1 Deg. C

Application Program Description

BREEZA Multi functions room controller

BREEZA_EXPORT_6_2 & 3

Communication Objects

Phys. Address	Description	Product	Order number	Program	Manufacturer	Seq	Adr	Prg	Pal	C	R	W	T	U
No.	Group Address	Function	Object name	Type	Priority									
01.01.011		SAVEOSTAT	ENSIA_A2W	BREEZA PW6_2	Ardan Production ...									
0		Set point temperature	2 Byte	Low	✓	✓	✓	✓						
1		Set point temperature status	2 Byte	Low	✓	✓								
2		Ambient temperature	2 Byte	Low	✓	✓								
3		Power	1 Bit	Low	✓	✓	✓	✓						
4		Power status	1 Bit	Low	✓	✓								
5		Set back	1 Bit	Low	✓	✓	✓	✓						
6		Night	1 Bit	Low	✓	✓	✓	✓						
7		Stand by status	1 Bit	Low	✓	✓								
8		Heat	1 Bit	Low	✓	✓	✓							
9		Cool	1 Bit	Low	✓	✓	✓							
10		IR movement detector	1 Bit	Low	✓	✓						✓		

Note: The order of the entries may vary from the above due to individual customization of the table.

Obj.	Object Name	Function	Type	Flags
0	Set Point Temperature	Remote regulation Set point command	2-byte	C W Receive
This object holds the specified temperature set point, which is sent via Bus telegram from remote.				
1	Set Point Temp. Status.	Local Actual regulation Set point	2-byte	C R T* Sent
This object holds the Actual specified temperature set point, Which was set at the operating panel of the controller or from remote. It also can be read 'manually' via the Bus or transmitted automatically according to the setting of the respective parameters.				
2	Ambient Temperature.	Actual Measured Room Temperature	2-byte	C R T* Sent
This object holds the actual temperature that is automatically sent on change of Temp. Or on time base as specify at the parameter settings. It also can be read 'manually' via the Bus.				

Application Program Description

BREEZA Multi functions room controller

BREEZA_EXPORT_6_2 & 3

3	Power.	Operating mode	1-bit	C W Receive
This object allows you to activate the HVAC controller via the Bus.				
4	Power Status.	Local Operating mode	1-bit	C R T* Sent
This object indicates the operation of the HVAC controller from the operating front panel of the controller. It also can be read 'manually' via the Bus.				
5	Set Back.	Status Mode Operation	1-bit	CW Receive
This object allows you to activate/deactivate the set back mode via the Bus.				
6	Night.	Operating mode	1-bit	CW Receive
This object allows you to activate (value = 1) or deactivate (value = 0) the night mode via the Bus. In this mode, the temperature is adjusted according to the setting of the respective parameters. An appropriate telegram could be sent by e.g. a time switch.				
7	Stand By Status.	Operating mode	1-bit	C R T* Sent
This object allows you to monitor the stand by mode via the Bus. Dependent on the parameter setting An appropriate telegram could be sent by the controller automatically on every change of the operation mode e.g.				
8	Heat.	Status Mode Switch	1-bit	C R W Receive/ Sent
This object allows or indicates a change between operating mode: value changes from 0 to 1 - operating mode changes from cooling to Heating or From ventilation to Heating. value changes from 1 to 0 - operating mode changes from heating to Cooling or From heating to ventilation. In case were a Cooling mode is active, the operation of the Heating will Change the value of the cooling to 0. The object is been Sent by the controller and received from remote as set at the parameters.				
9	Cool.	Status Mode Switch	1-bit	C R W Receive/ Sent
This object allows or indicates a change between operating modes: Value changes from 0 to 1 - operating mode changes from heating to Cooling or From ventilation to cooling. value changes from 1 to 0 - operating mode changes from cooling to Heating or From cooling to ventilation. In case were a Heating mode is active, the operation of the Cooling will Change the value of the Heating to 0. The object is been Sent by the controller and received from remote as set at the parameters.				

Application Program Description

BREEZA Multi functions room controller

BREEZA_EXPORT_6_2 & 3

10	I/R Movement detector.	Operating mode	1-bit	C W* R*T* Receive/ Sent
This object allows the operation of the stand by mode via the Bus. By using a remote presence detector. An appropriate telegram could be sent from remote to the presence algorithm, Another application allows internal presence detector connection to the controller and then the presence signal enters direct to the controller and the Bus can only read status.				
11	Light Control	Operating mode	1-bit	CRWT Receive/ Sent
This object allows you to switch via the Bus remote Binary Output connected to e.g. Light unit. Pressing on the Light button switch at the controller operation panel could send an appropriate telegram.				
12	Under floor heater	Operating mode	1-bit	CRT /Send
This object control the under-floor heater switching ON/OFF, depending on the room temperature and set point measured plus the under-floor safety temperature measured.				

Note: Not all Objects are available on each application. Objects that are not Relevant to the application will not show on the screen.

Maximum number of group addresses: 22

Maximum number of assignments: 37

Application Program Description

Parameters

PARAMETERS, are divided in to 5 screens,

When starting the parameters setting,
First, the panel of the controller must be defined.

There are 25 panels to select from,

Panels 0 to 15 are MCO = Manual Change Over ones with COOL and HEAT buttons.
Panels 16 to 25 are ACO/RCO = Automatic Change Over and Remote Change Over ones,

Every Parameter has default setting, and the installer must check that the parameters are matching to the equipment that is being used,

The HVAC equipment, Present detector, window or door switches and the Light switch elements.

The Basic Screen

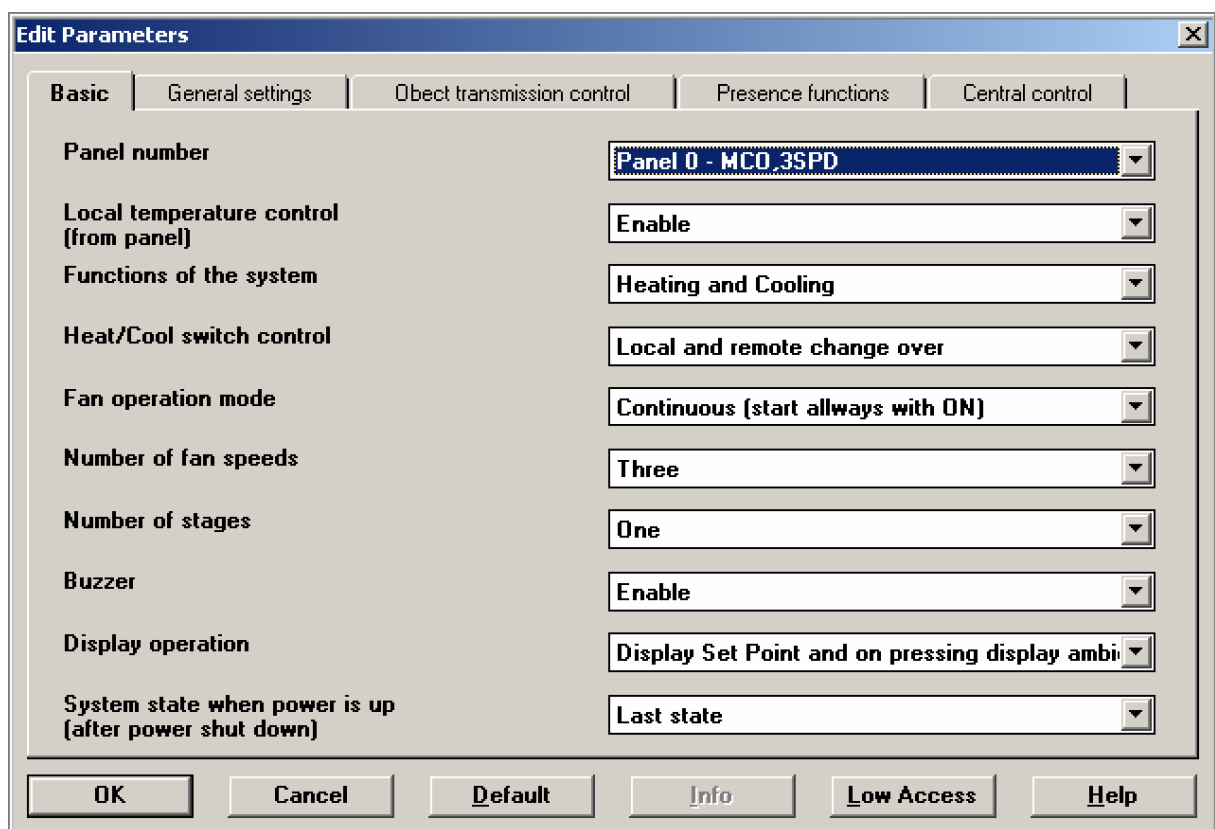

Application Program Description

BREEZA Multi functions room controller

BREEZA_EXPORT_6_2 & 3

There are 26 panels to select from; The Panel defines the basic application and operation of the system and Push buttons. The two leftmost buttons are always dedicated to increase/decrease the Set Point Temperature. The ETS parameter "**Local temperature control**" Enable/Disable those two buttons.

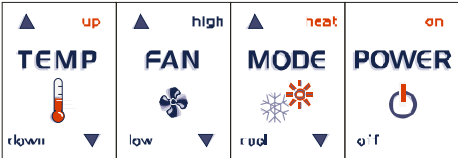
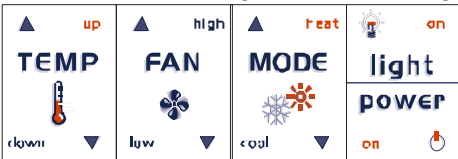
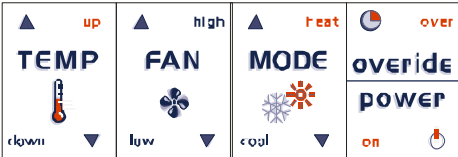
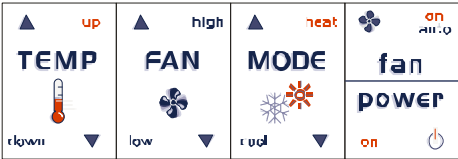
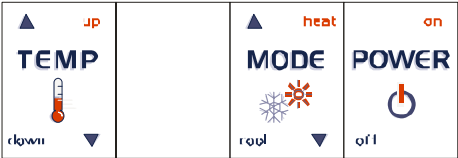
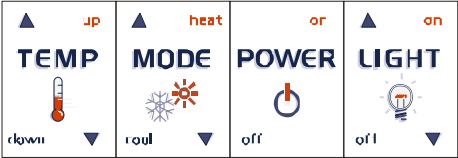
Parameter	Default Settings
Panel Number	0
<p>Panel #0 = Heat, Cool, Fan High, Fan Low, Power On, Power Off buttons.</p> 	
<p>Panel #1 = Heat, Cool, Fan High, Fan Low, Light On/Off* and Power On/Off* Buttons.</p> 	
<p>Panel #2 = Heat, Cool, Fan High, Fan Low, Override On/Off* and Power On/Off* buttons.</p> 	
<p>Panel #3 = Heat, Cool, Fan High, Fan Low, Fan On/Auto* and Power On/Off* Buttons.</p> 	
<p>Panel #4 = Heat, Cool, Power On, Power Off buttons. (1 Fan Speed).</p> 	
<p>Panel #5 = Heat, Cool, Light On, Light Off, Power On, Power Off buttons. (1 Fan Speed).</p> 	
<p>Panel #6 = Heat, Cool, Override On/Off*, Light On, Light Off and Power On/Off* Buttons. (1 Fan Speed).</p>	

Application Program Description

BREEZA Multi functions room controller

BREEZA_EXPORT_6_2 & 3

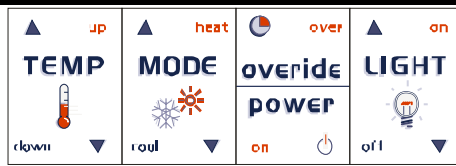

Panel #7 = Heat, Cool, Override On/Off*, Power On, Power Off buttons. (1 Fan Speed).

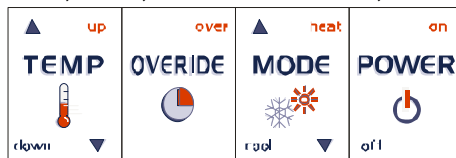

Panel #8 = Heat, Cool, Fan On, Fan Auto, Power On, Power Off buttons. (1 Fan Speed).

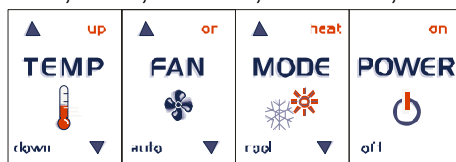

Panel #9 = Heat, Cool, Fan On/Auto*, Light On, Light Off, Power On/Off* Buttons. (1 Fan Speed).

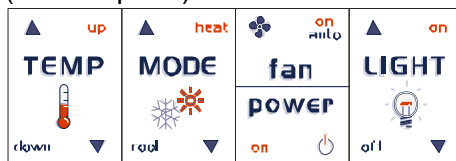

Panel #10 = Heat (AC+ Under floor heatr), Cool, Fan On/Auto*, ACO/MCO (Automatic/Manual) Changeover*, Turbo*, Power On/Off* Buttons. (1 Fan Speed).

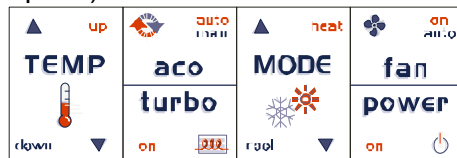

Panel #11 = Heat, Cool, Light On/Off*, Power On/Off*, ACO/MCO (Automatic/Manual) Changeover*, Turbo* Buttons. (1 Fan Speed).



Panel #12 = Heat, Cool, Override On/Off*, ACO/MCO (Automatic/Manual) Changeover*, Turbo*, Power On/Off* buttons. (1 Fan Speed).

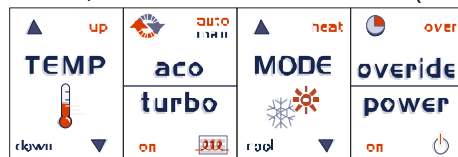

Panel #13 = Fan On, Fan Auto, Power On, Power Off buttons.
This panel is an Auto Heat/Cool changeover with 1 Fan Speed.

Application Program Description

BREEZA Multi functions room controller

BREEZA_EXPORT_6_2 & 3



Panel #14 = Fan On, Fan Auto, Light On and Off, Power On, Power Off buttons.
This panel is an Auto Heat/Cool changeover with 1 Fan Speed.

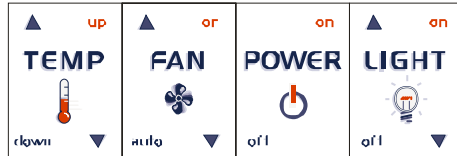

Panel #15 = Fan On, Fan Auto, Override On/Off*, Light On, Light Off, Power On/Off* Buttons. This panel is an Auto Heat/Cool changeover with 1 Fan Speed.



Panel #16 = Fan On, Fan Auto, Override On/Off*, Power On, Power Off buttons.
This panel is an Auto Heat/Cool changeover with 1 Fan Speed.



Panel #17 = Fan High, Fan Low, Power On, Power Off buttons.
This panel is an Auto Heat/Cool changeover.



Panel #18 = Fan High, Fan Low, Light On, Light Off, Power On, Power Off buttons.
This panel is an Auto Heat/Cool changeover.

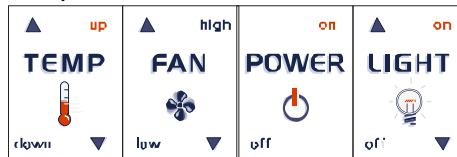

Panel #19 = Fan High, Fan Low, Light On and Off, Override On/Off*, Power On/Off* Button. This panel is an Auto Heat/Cool changeover.



Panel #20 = Fan High, Fan Low, Override On/Off*, Power On, Power Off buttons.
This panel is an Auto Heat/Cool change over.

Application Program Description

BREEZA Multi functions room controller

BREEZA_EXPORT_6_2 & 3

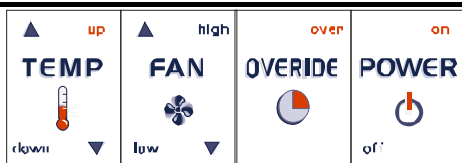

Panel #21 = Fan High, Fan Low, Fan On/Auto*, Light On, Light Off, Power On/Off* Buttons. This panel is an Auto Heat/Cool change over.

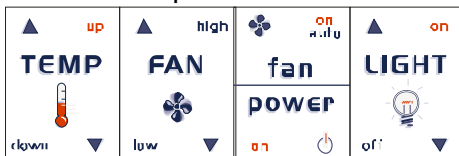

Panel #22 = Fan High, Fan Low, Fan On, Fan Auto, Power On, Power Off buttons. This panel is an Auto Heat/Cool change over.

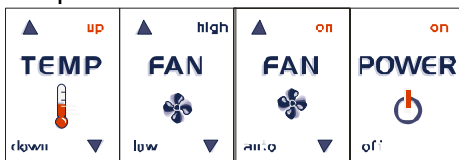

Panel #23 = Power On, Power Off buttons. This panel is an Auto Heat/Cool change over with 1 Fan Speed.



Panel #24 = Light On, Light Off, Power On, Power Off buttons. This panel is an Auto Heat/Cool change over with 1 Fan Speed.

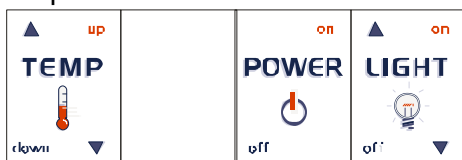

Panel #25 = Light On, Light Off, Fan On, Fan Auto, Override On/Off*, Power On/Off* Buttons. This panel is an Auto Heat/Cool change over with 1 Fan Speed.



* = Every Button that has the * mark is a toggle button which switches Between The two function on each press.

Application Program Description

BREEZA Multi functions room controller

BREEZA_EXPORT_6_2 & 3

Parameter	Default Settings
Local temperature control	Enable
This parameter enables and disables the operation of the leftmost up and down BREEZA buttons.	
Function of the system	Heating and Cooling
This parameter allows the setting of the operation mode, 3 options are available: <ul style="list-style-type: none"> - Heating and Cooling - Heating only - Cooling only. 	
Heat / Cool Switch Control	Local and Remote Change over
When set to "heating and cooling" mode, changing from heating to cooling or vice versa is established in one of three possible ways: <ul style="list-style-type: none"> - From the controller operation panel by using the buttons - Automatically according to ambient temperature - Manually via the Bus (object [8 and 9]). This parameter allows defining which options out of the three is desired in your application (notice – not all functions are available for all panels).	
Fan Operation Mode	Continuous
At this parameter, the Fan operation is define, were the fan can run: <ul style="list-style-type: none"> - Continuously all the time - Run only while there is a demand for Heating or Cooling (Auto) - Run on Cooling continuously and on Heating run (Auto) per demand. 	
Number of Fan speeds	Three
According to the Panel selection, and if a multi Fan Speed panel was selected, this parameter allows the setting of speed number that will be available for the Fan. (This parameter influence the "Number Of Stages" parameter: Number of fan speeds + the number of stages can not be more then 4).	
Number Of Stages	One
According to the panel selection, the numbers of controlled HVAC stages will be define. The "Number Of fan speeds" influences this parameter. Number of fan speeds + the number of stages can not be more then 4).	
Buzzer	Enable
This parameter enables and disables the operation of the internal Buzzer that beeps every time one of the buttons is being pressed.	
Display Operation	Display Set point and on pressing display Ambient
This parameter defines what will be displayed on the 3-digit LCD display at the front of the controller. 4 options are available: <ul style="list-style-type: none"> - Display Set point and on pressing display Ambient - Display Ambient and on pressing display Set point - Display Set point Only - Display Ambient Only. 	

Application Program Description

BREEZA Multi functions room controller

BREEZA_EXPORT_6_2 & 3

Parameter	Default Settings
System state when power is up (After power shut down).	Last state
<p>This parameter defines the operation of the controller after power turns ON, Two options are available: Controller will start working in the same Power operating mode as before the power was turn OFF (if power was ON the controller will be ON. If power was OFF, The controller will be OFF).</p> <p>The second option ("Start/Stop") will always be OFF when the Power to the controller is applied, The controller will start only by pressing the power button.</p>	
Under Floor Heater (Panel #10 only)	Disable
<p>This parameter Enables/Disables the Underfloor heater operation. The parameter settings are:</p> <p><u>-Disable</u>: Underfloor heater operation is disabled. <u>-Enable</u>: Underfloor heater operation is enabled. In that case Underfooor heater control object appears on the configuration screen. The underfloor temperature sensor can be conected to the controller as a saftey control option. The application can work without the saftey underfloor sensor.</p>	

The General Setting Screen

The screenshot shows a software dialog box titled "Edit Parameters" with a close button (X) in the top right corner. The dialog has five tabs: "Basic", "General settings" (which is selected), "Object transmission control", "Presence functions", and "Central control". The "General settings" tab contains the following parameters, each with a dropdown menu:

- Units of measurement: Celsius
- Duration of time between cyclic temperature status transmissions: No cyclic transmission
- Temperature change that generates automatic transmission on the Bus: Disable
- Remote control channel: Remote control not used
- Minimum set-point on cooling (must be less than max. set-point): 10° Celsius
- Maximum set-point on heating (must be greater than min. set-point): 32° Celsius
- 5 minutes delay before compressor runs again: Disable
- Air conditioner type: Direct type
- Winter/Summer control: Disable

At the bottom of the dialog, there are six buttons: "OK", "Cancel", "Default", "Info", "High Access", and "Help".

Application Program Description

BREEZA Multi functions room controller

BREEZA_EXPORT_6_2 & 3

Parameters	Default Settings
Units of measurements	Celsius
The units of measurement are selected in this parameter, Celsius or Fahrenheit.	
Duration time between cyclic temp. transmissions	No Cyclic Transmission
This parameter defines the time period between cyclic transmissions of Ambient temperature on the Bus. The cyclic time period can be selected from 3 minutes and up to 60 minutes.	
Temperature Change that generate Automatic transmission on the Bus.	Disable
This parameter defines the value of change in temperature that will generate a transmission on the Bus. The value of change can be set from 0.5 to 2.0 Deg. K	
Remote Control	Not Used
Minimum Set Point on Cooling	10° Celsius
This parameter defines the lower limit of the set point while operating in the Cooling mode. The lower range can be set from 5°C upto 32°C, It must be less than the Maximum set point value	
Maximum Set Point on Heating	32° Celsius
This parameter defines the higher limit of the set point while operating in the Heating mode. The higher range can be set from 5°C upto 32°C, It must be greater than the Minimum set point value	
5 Minutes Delay before Compressor operation	Disable
This parameter defines the use of a compressor safety feature that allows a 5 minutes delay after the compressor turns OFF to the next time there is a demand to operate the compressor. The Default setting depends on the type of the HVAC, Heat pump units uses compressors and most of installation they will need the protection of 5 minutes delay. Fan coils do not use compressors and they will not have this delay in the default settings.	
Air Conditioner type	Direct Type
This parameter defines the type of the HVAC unit that the controller is going to take control on. The parameter selects between the two major HVAC units' type. Fan-Coil and Heat Pump. Fan-Coils units are Direct Type and the have a direct operation of the Cool and Heat outputs. The Heat Pump options are used for all kind of Heat Pumps units, Heat Pump with reversing valve that activates in the Cool mode and Heat pump with the reversing valve activated in the Heat mode operation.	

The Object Transmission Control Screen

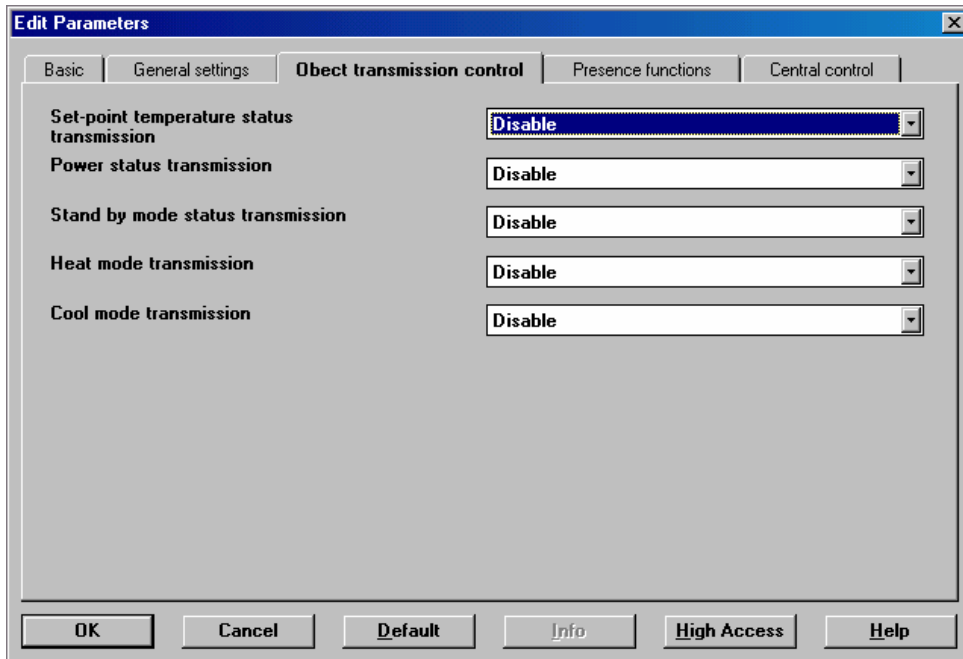

Parameters	Default Settings
Set-Point Temperature transmission	Disable
This parameter defines if the Set-Point Temperature value will be transmitted on the Bus or not.	
Power Status Transmission	Disable
This parameter defines if the Power Status will be transmitted on the Bus or not.	
Stand By mode Status transmission	Disable
This parameter defines if the Stand by mode status will be transmitted on the Bus or not.	
Heat Mode Transmission	Disable
This parameter defines if the Heat Mode Status at the BREEZA controller will be transmitted on the Bus or not.	
Cool Mode Transmission	Disable
This parameter defines if the Cool Mode Status at the BREEZA controller will be transmitted on the Bus or not.	

The Presence Functions Screen

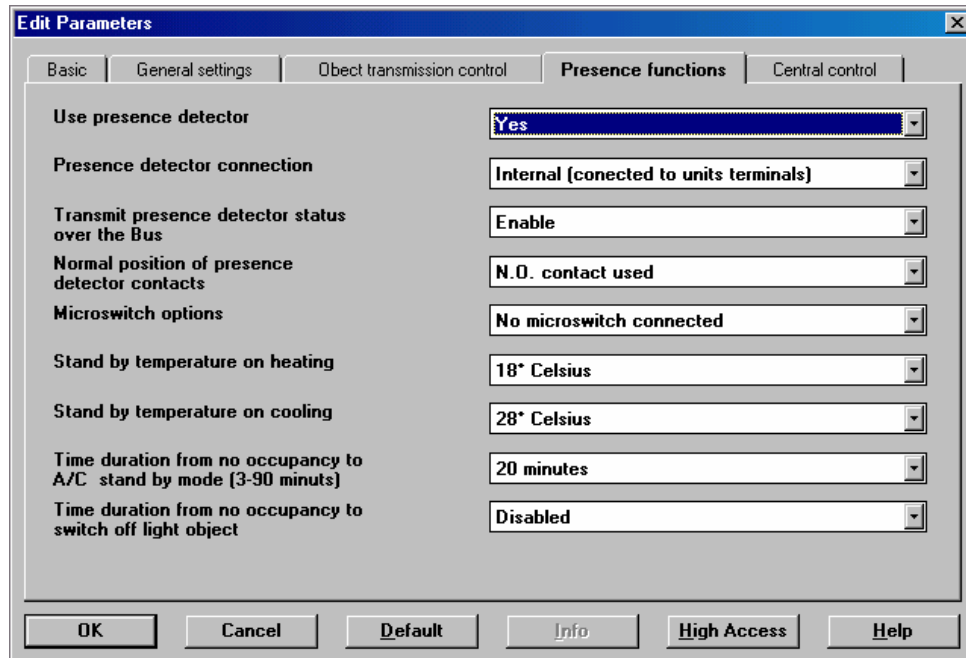

Parameters	Default Settings
Presence Detector	Yes
This parameter defines if the controller will use the presence detector functions or not.	
Presence Detector Connection	Internal
This parameter defines if the Presence detector will be connected directly in to the BREEZA controller or will be an external Presence detector that will transmit the status on the Bus to the BREEZA controller.	
Transmit presence detector status on the Bus	Enable
This parameter defines if the Presence detector Status will be transmitted on the Bus.	
Normal Position of presence Detector Contacts	N.O. =Normally Open
This parameter defines the type of presence detector contact that is being used. If the contact is a Normally open one or is a normally close one.	
Micro Switch Options	No Micro Switch Connected
This parameter defines if a micro Switch is connected to the BREEZA controller or not, Only one micro switch can be connected to a controller. It can be a Door Switch, which works along with the presence detector and enters in to the Presence algorithm. A window switch can be selected and this switch when ever is open, Shut down the all BREEZA outputs.	
Stand By Temperature on Heating	18° Celsius
This parameter defines the Temperature Set Point while the controller operates in the Heating mode and enters to the Stand By Mode.	

Application Program Description

BREEZA Multi functions room controller

BREEZA_EXPORT_6_2 & 3

Parameters	Default Settings
Stand By Temperature on Cooling	28° Celsius
This parameter defines the Temperature Set Point while the controller operates in the Cooling mode and enters to the Stand By Mode.	
Time Delay from No presence till HVAC enters the stand By Mode.	20 Minutes
This parameter defines the time duration from controller detects no occupancy in the room tell the controller enter the Stand By Mode.	
Time Delay from No presence to Switch OFF the Light Object.	Disabled
This parameter defines the time duration from the moment the controller will detect no occupancy in the room tell the controller Switch OFF the Light Object.	

The Central Control Screen

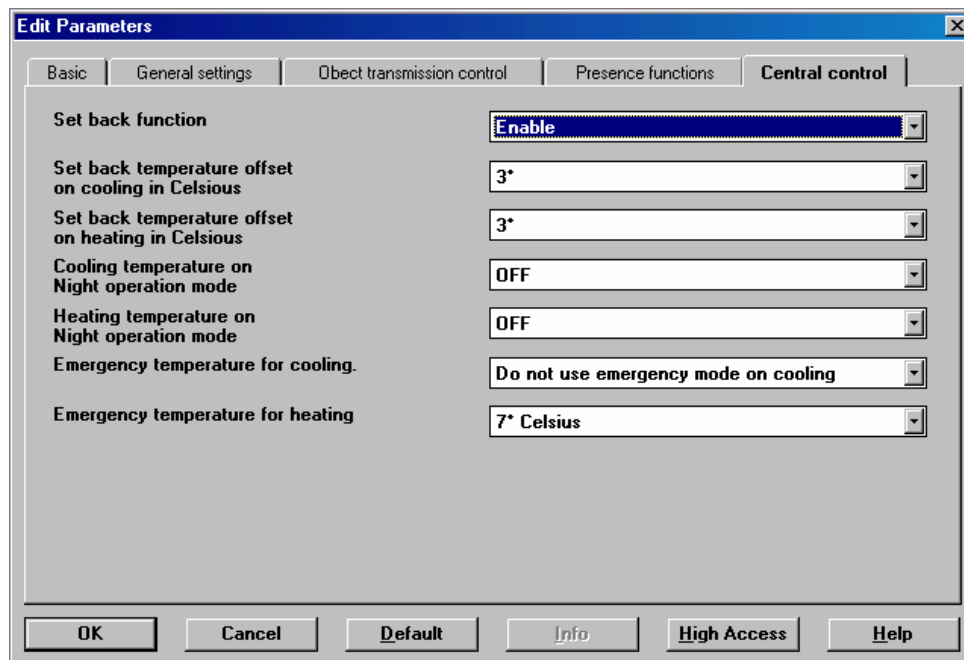

Application Program Description

BREEZA Multi functions room controller

BREEZA_EXPORT_6_2 & 3

Parameters	Default Settings
Set Back Function	Enable
<p>This parameter defines if the Set Back function will be used or not. The Set Back function allows the controller to have an Energy saving option.</p>	
Set Back Temperature Offset on Cooling	DISABLE
<p>This parameter defines the set back value in degrees K. The Set Back function is an Energy saving option. When set back object value is 1 the BREEZA controller will decrease energy consumption by raising the original cooling set point temperature with the set back value that is define in this parameter. This value can be changed from 1°K to 9°K or Disable. If it is set to “Disable” the Set Back function will not be used. Set Back operation does not influence the set point display.</p>	
Set Back Temperature Offset on Heating	DISABLE
<p>This parameter defines the set back value in degrees K. The Set Back function is an Energy saving option. When set back object value is 1 The BREEZA controller will decrease energy consumption by lowering the original set point for heating (minus) with the set back value that is define in this parameter. This value can be changed from 1°K to 9°K or Disable. If it is set to “Disable” the Set Back function will not be used. Set Back operation does not influence the set point display.</p>	
Cooling Temperature on Night Operation mode	DISABLE
<p>When the controller operates in the Cooling mode and entering in to the Night mode, A preset set point value is entered to be the new set point during the Night mode operation. This value can be change from 25°C to 36°C.</p>	
Heating Temperature on Night Operation mode	DISABLE
<p>When the controller operates in the Heating mode and entering in to the Night mode, A preset set point value is entered to be the new set point during the Night mode operation. This value can be change from 5°C to 20°C.</p>	
Emergency Temperature for Cooling	DISABLE
<p>This parameter defines the Temperature Set Point value that will operate the controller in Emergency Mode when working on Cooling mode. In Emergency mode, the controller will maintain the preset set point temperature value. This value can be change from 21°C to 36°C. This function is activ even when the Multi function room controller is set in the OFF position as long as power is connected.</p>	
Emergency Temperature for Heating	7°C
<p>While the controller is originally set to work on Heating mode and even when the Multi function room controller is set in the OFF position as long as power is connected. This parameter defines the Temperature Set Point value that will operate the controller in Emergency Mode. In Emergency mode, the controller will maintain the temperature around the preset set point value. This value can be change from 3°C to 15°C.</p>	

Installation Instructions

Figure 1:

Location of the display and operator elements

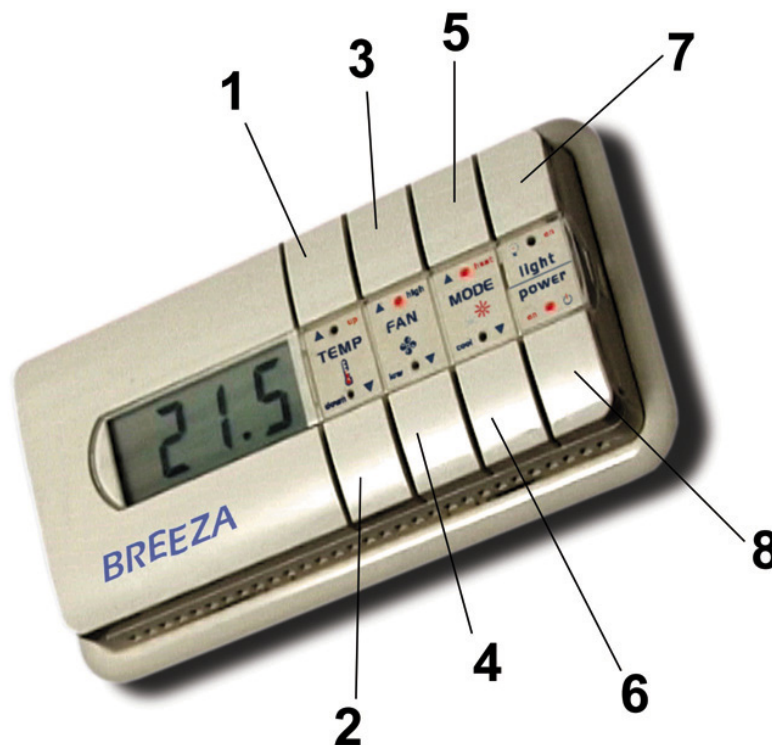

1. Push button for manual **up** set point adjustment.
2. Push button for manual **down** set point adjustment.
3. Push button for higher Fan speed selection or other features as defined in the selected panel.
4. Push button for lower Fan speed selection or other features as defined in the selected panel.
5. Push button for Heat mode selection or other features as Defined in the selected panel.
6. Push button for Cool mode selection or other features as Defined in the selected panel.
7. Push button for Power ON or Light ON/OFF operation or as defined in the selected panel.
8. Push button for power OFF or as defined in the selected panel.

Instructions for Installation and Operation

TAA

The Multi function room controller may be used for permanent interior installations in dry locations within box mounts.

The installation of the BREEZA Multi function room controller must be in accordance with the regulations of ALL Authorities having jurisdiction and MUST conform to all applicable Codes.

It is the responsibility of the Installing Contractor to determine and comply with ALL applicable Codes and Regulations.

Installer MUST be an experienced service technician trained in the installation of this type of equipment.

Pre-Installation

Before start- up, read all manuals and become familiar with the BREEZA Multi function room controller Installation, operating and maintenance instructions and its operation. Verify that the HVAC unit to be controlled by the BREEZA is installed and ready for operation.

Check the applications and correctly match the BREEZA parameters with the HVAC unit and other elements to be controlled and monitored.

Field supplies and install electrical mounting boxes following location instructions listed below.

Determine which of the field wiring diagrams is to be used.

Location of the BREEZA unit in a room

Install the BREEZA Multi function room controller approximately 1.50 meters (5 feet) above the floor in an area exposed to circulating room air of average room temperature.

The BREEIZA Multi function room controller must be installed in accordance with the following guidelines:

- Install on an interior wall only. Do not install on an exterior wall.
- Install out of direct sunlight.
- Install at some distance from air discharge grilles. Do not directly expose to hot or cold discharge air.
- Install out of drafty areas and dead air spaces.

Instructions for Installation and Operation

TAA

Dimensions

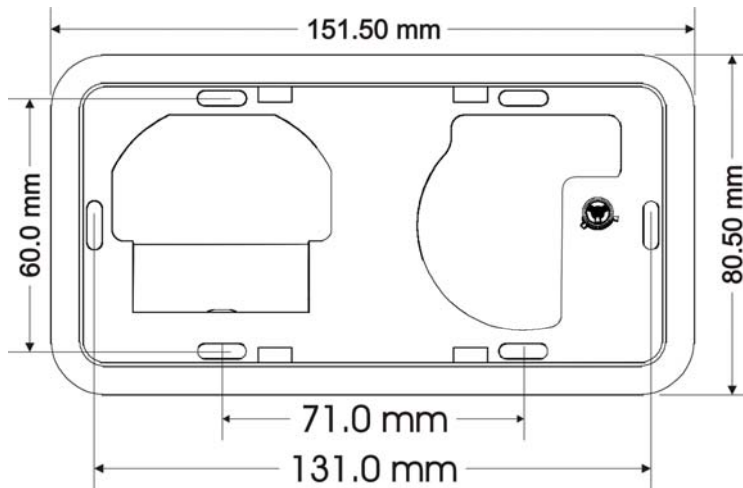

Dimensions: W x H: 151.5 x 80.5 mm

Depth: 32 mm

Mounting depth: 11 mm

Mounting

Mount the BREEZA Multi function room controller as shown in figure 2.

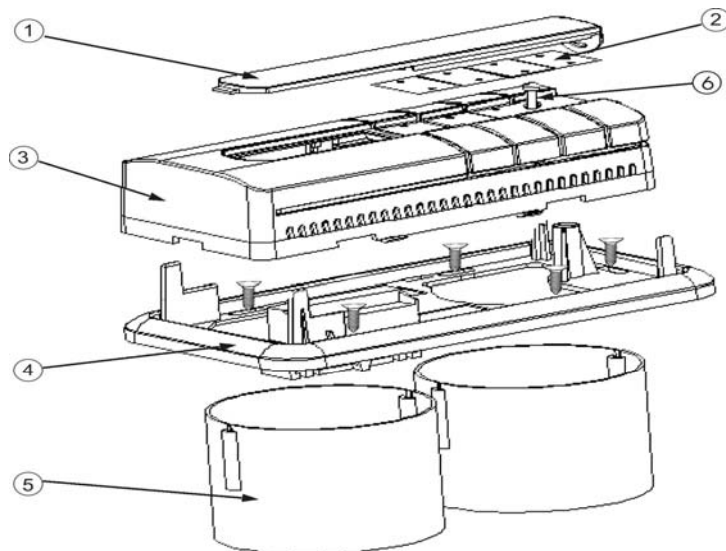

1. Transparent cover
2. Label pictograms
3. Front cover
4. Back plate
5. Wall box
6. Screw

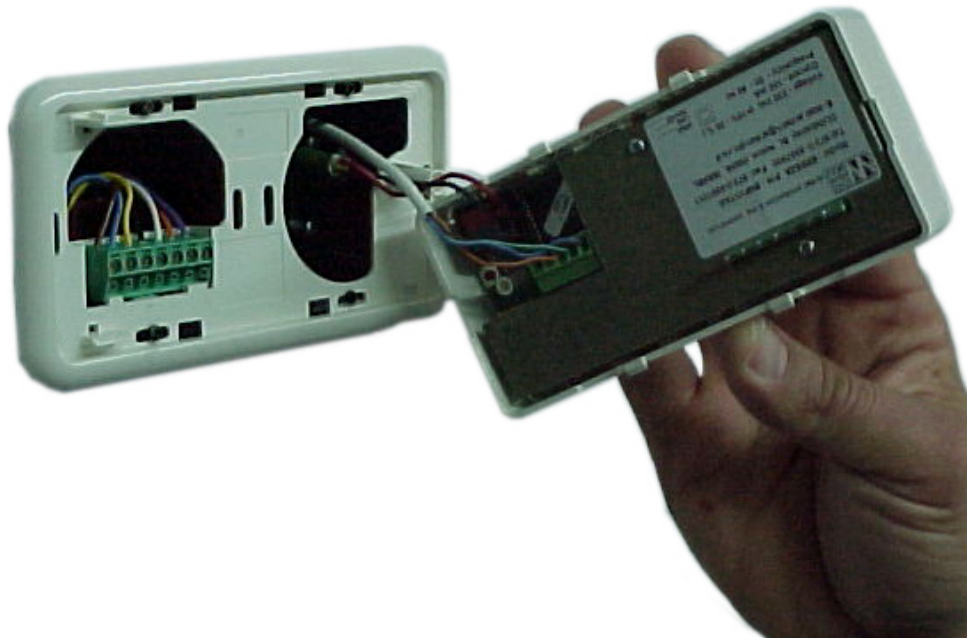

Figure 2:

BREEZA Installation

1. Remove the BREEZA Multi function room controller from the shipping carton.
2. Check part number on the back to ensure that it is correctly matched to the unit to be controlled.
3. Remove the BREEZA back from the front part by removing the screw under the clear front part (3).
4. Match the appropriate labels to the panel you had selected and attach them to the back slot of the clear plastic cover.
5. Install the clear part with the labels to the location by pressing it.
6. Pull the control wire through the right back plate hole.
7. Pull the power wire through the left back plate hole.
8. Attach the BREEZA back plate to the field supplied and installed electrical boxes using the four screws provided.
9. Connect the control wires to the 5 Pin's connector at the BREEZA back, per the appropriate wiring diagram. Attach only one wire per terminal.
10. Assign Bus Address and download the ETS application to the BREEZA.
11. Connect the power wires to the 7 Pin's connector at the BREEZA back, per the appropriate wiring diagram. Attach only one wire per terminal.
12. Replace the front cover back to the back plane and close the screw under the clear part.

WARNING

- The unit must be mounted and commissioned by an authorized electrician.
- The prevailing safety rules must be heeded.
- The unit may be mounted in box mounts together with 230 V devices and/or 230 V cables. Watch out that the left side is a 230 volts wiring and the right side are for low voltage and control wiring.
- The unit must not be opened.
- A unit suspected faulty should be returned to the local ARDAN office.
- The prevailing safety rules must be heeded.

Wiring

WARNING

Connecting / Disconnecting the power supply and load line (HVAC)

- *Connecting L, N and HVAC terminals:*
The 7 pin 's terminals can be used with multi core wires $\varnothing 1 \dots \varnothing 1.5\text{mm}$
Remove about 6mm of insulation from the wire and enter it to the terminal hole and then close the screw.
- *Disconnect L, N and HVAC terminals:*
Open the screw of each terminal and remove the wire from the terminal.

Connecting the bus cables

- The bus connection block is situated in the right connection compartment.
- The bus-connecting block can be used with single core conductors $\varnothing 0.6 \dots 0.8 \text{ mm}$.
- Remove approx. 5 mm of insulation from the conductor and plug it into the bus connection block at the backside of the BREEZA unit.
- Red wire = +, Black wire = - .

Remote Sensor:

An optional, only Ardan's, remote sensor can be installed with the BREEZA Multi function room controller equipped with a four pin's connector mounted inside the unit for that purpose. Before connecting the temperature sensor remove the jumper in connector JP4.

The following sensors are available:

Remote room sensor with 100cm pre- formed cable Part No. **RTSR01**.

Remote room sensor with 16 Meters pre- formed cable Part No. **RTSR16**.

Remote under Floor sensor with 6 Meters pre- formed cable Part No. **RTSU06**.

BREEZA Wiring diagram

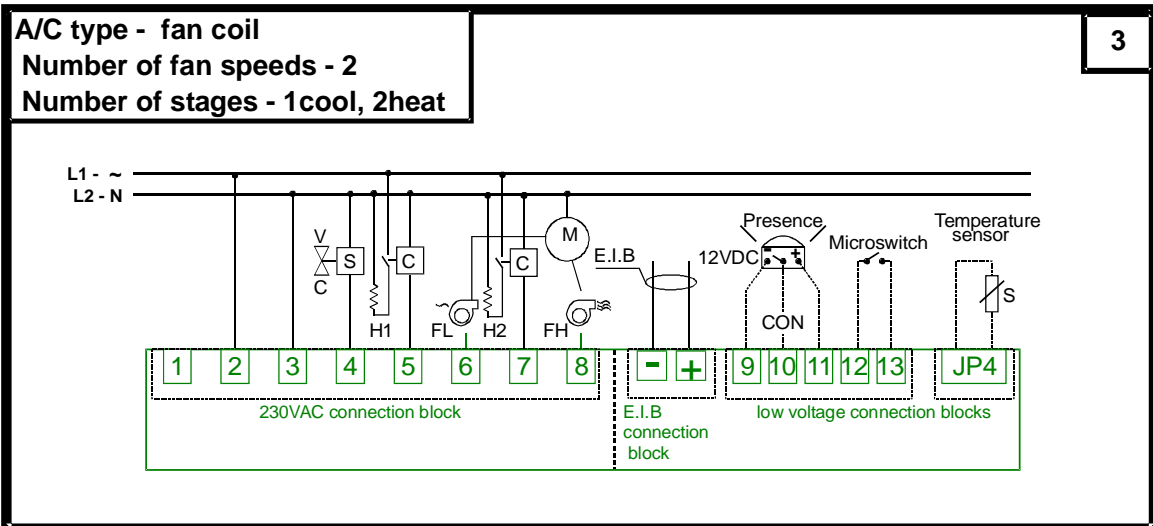
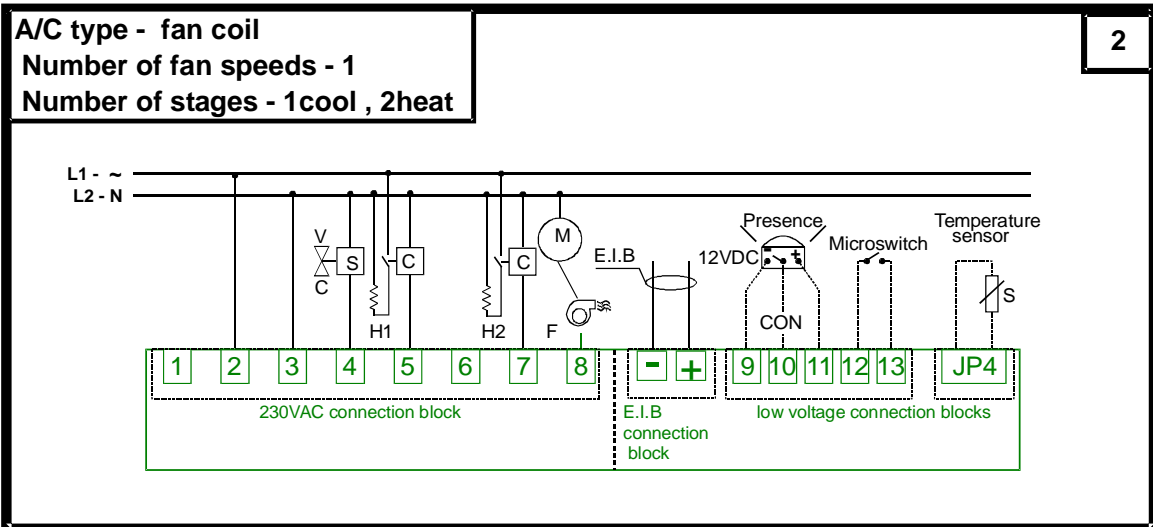
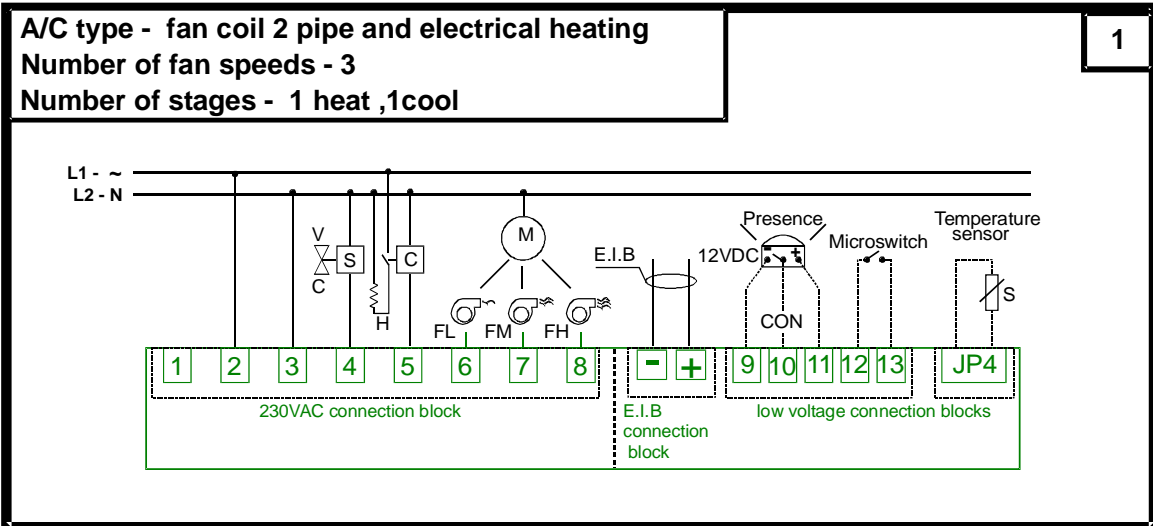

BREEZA Wiring diagram

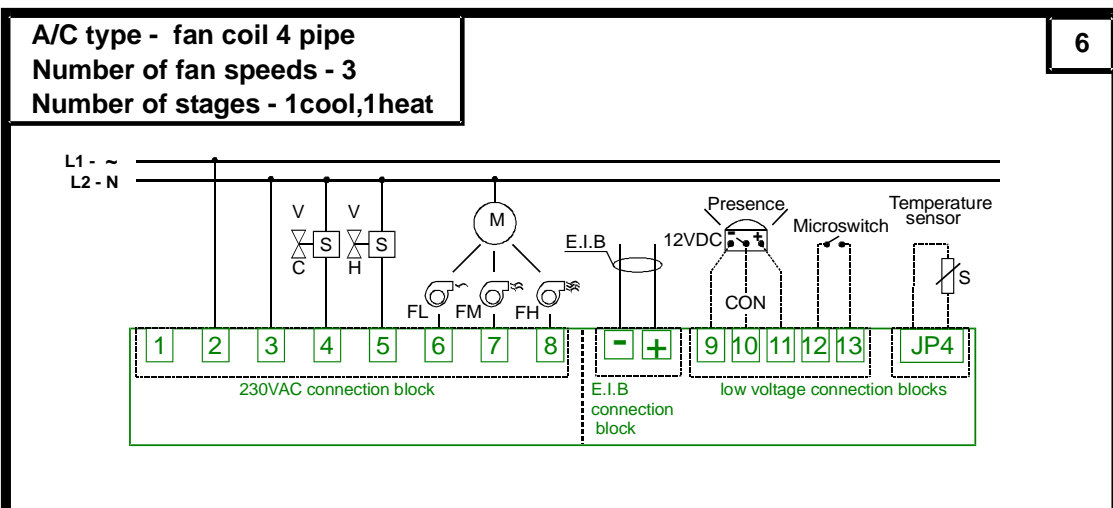
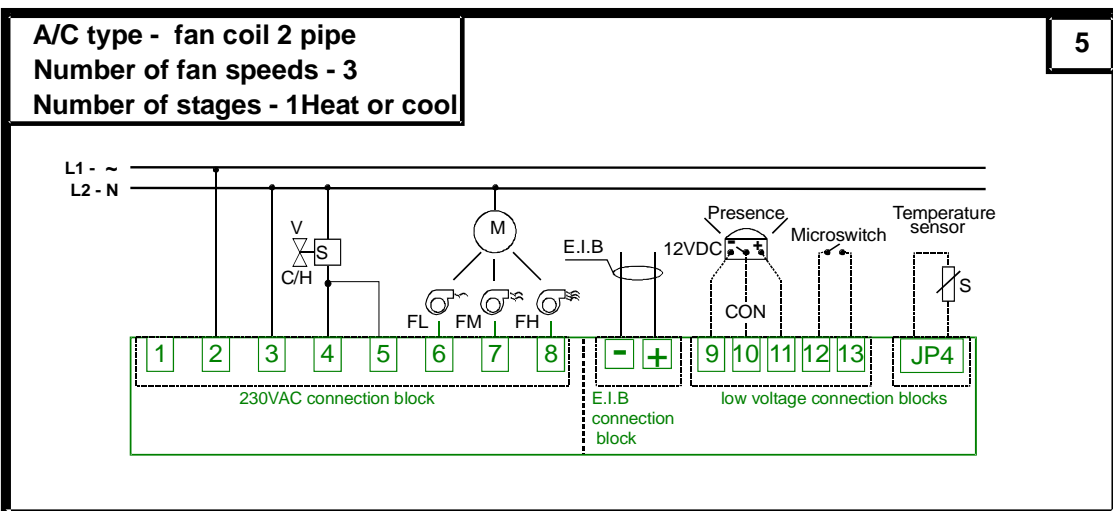
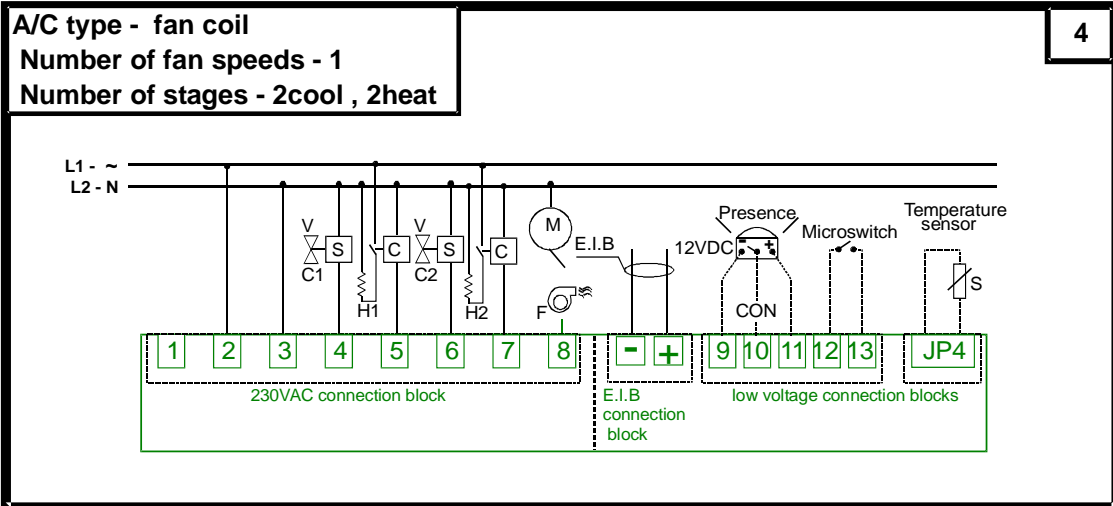

BREEZA Wiring diagram

